



红外线感应零件识别平台

型号: XKC-003K4





XKC-003K4

1. : ,



	DC5-12V
	< 200uA
	(3.3V/ 0V) /NPN/ (/) / 2A LED
	L /H ()
	5S (5-300S)
	1S
	32mm*24mm
	52L*36W*23H mm (), 2.5
	28 cm
	<110
	7
	-20~85
	:23mm ()

序号	型号	输出符号
1	XKC-003K4-V	(3.3V/ 0V) < 3mA
2	XKC-003K4-N	NPN () < 300mA
3	XKC-003K4-M	() 3A
4	XKC-003K4-MC	() 3A
5	XKC-003K4-LED 2A	LED 2A

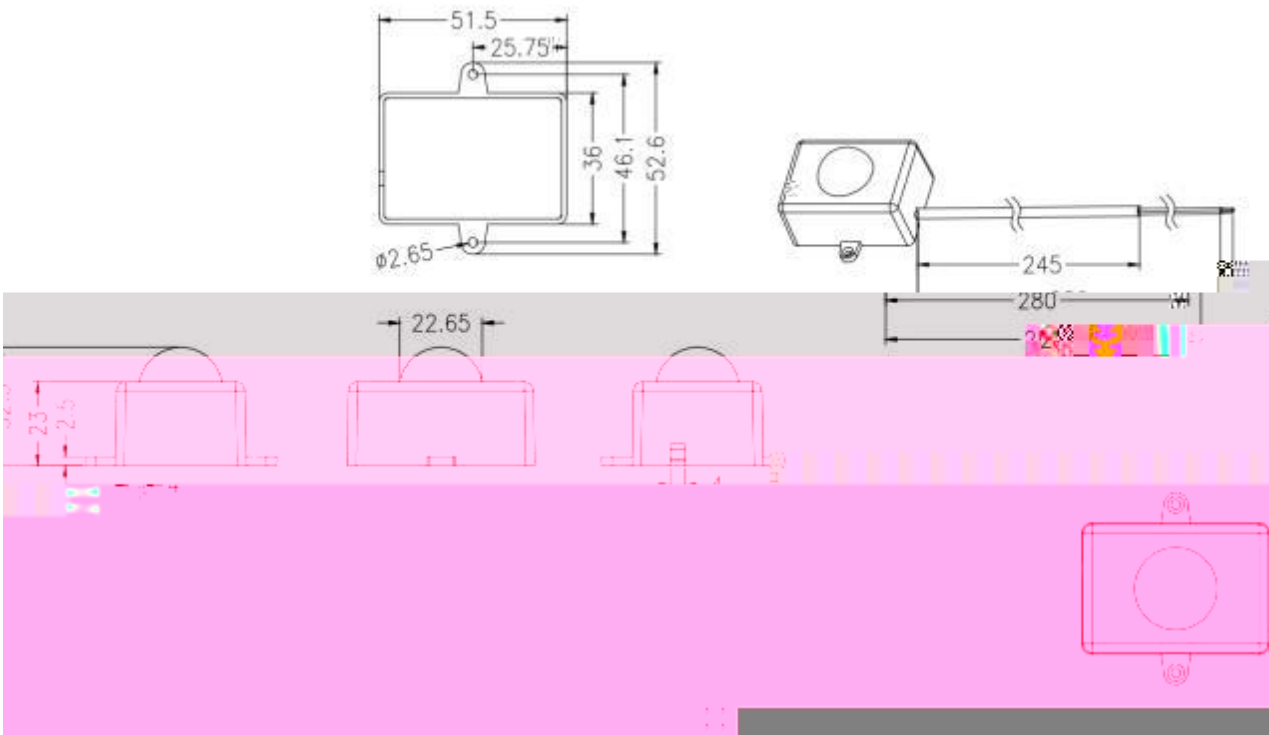

2. XKC-003K4-LED2A

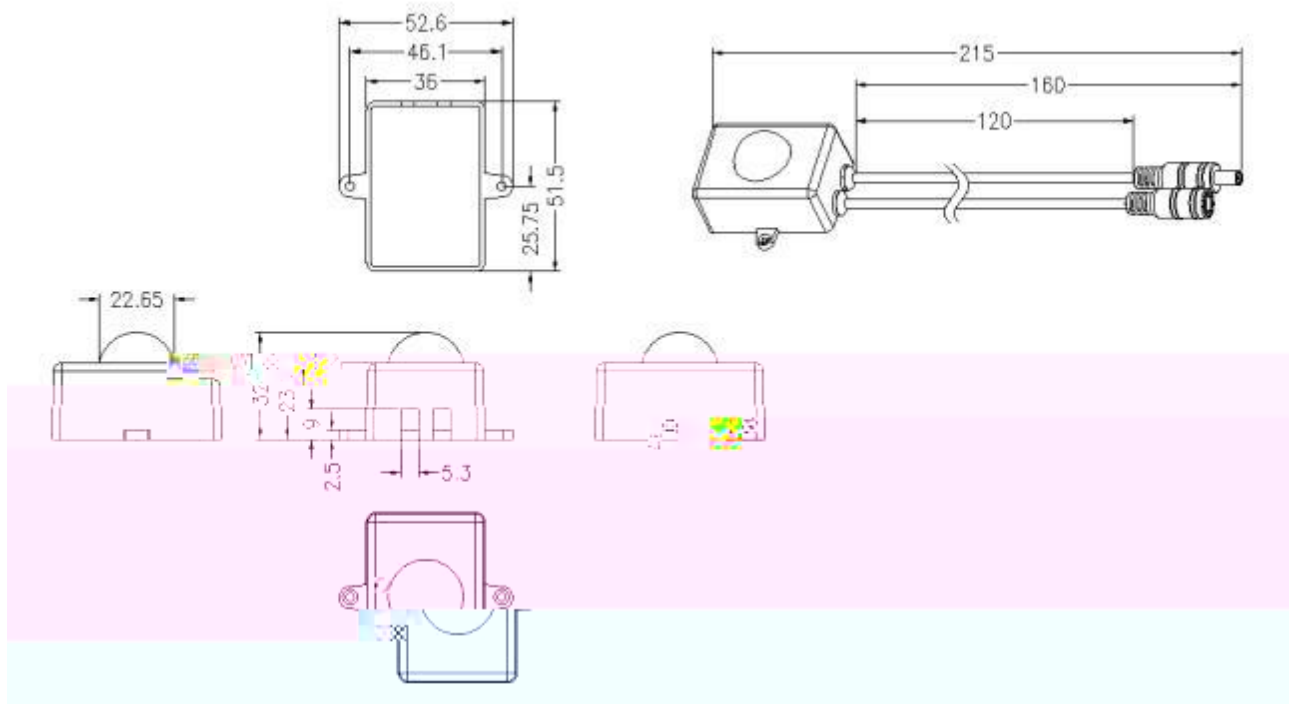

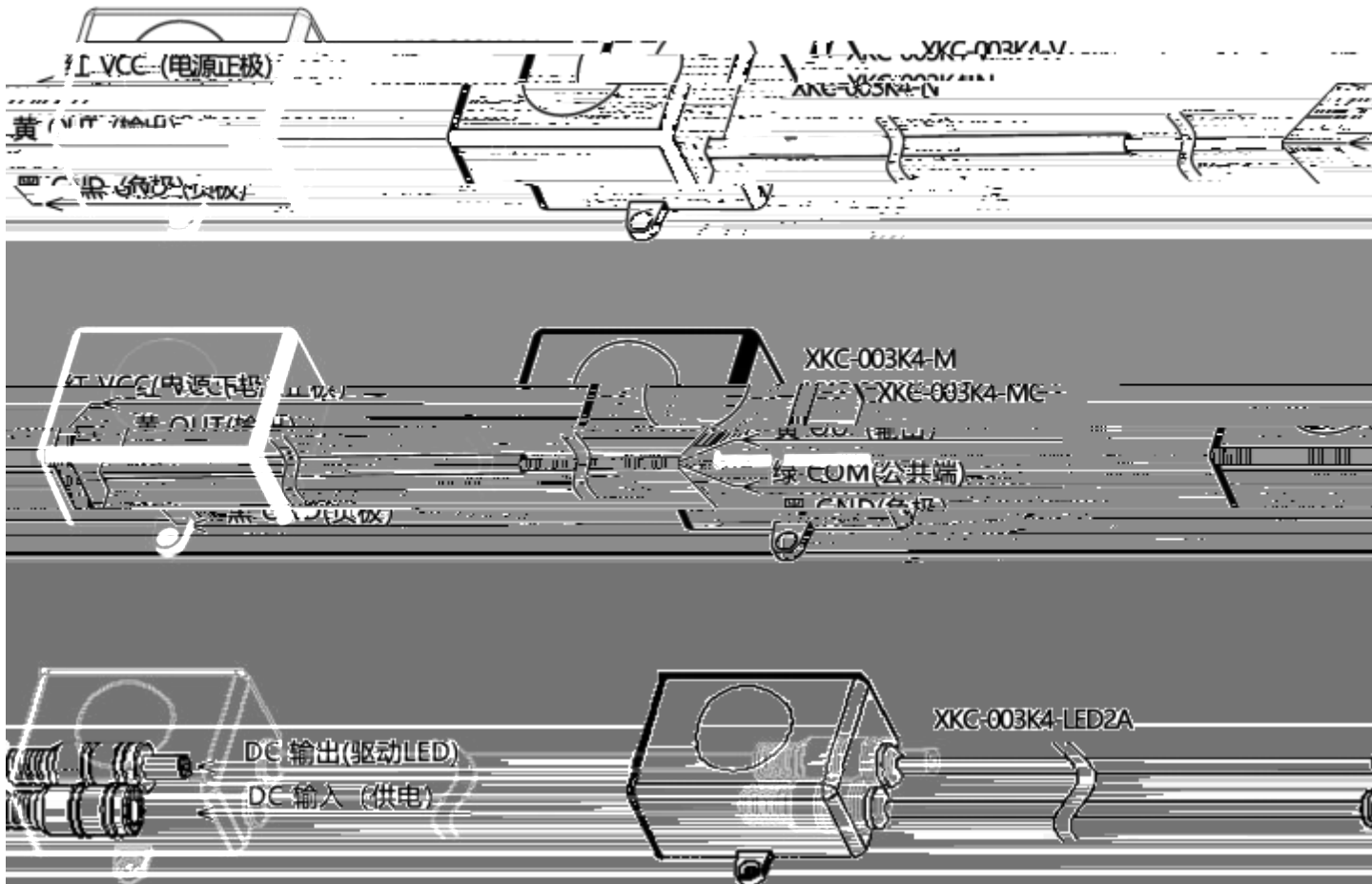

(3); (7);
(5S); (300S);



1.		1. ; 2.OUT ; 3. ; 4.L ; H ; 5.CDS ; 6.Time ; 7.Distances
2.		
3.		

()

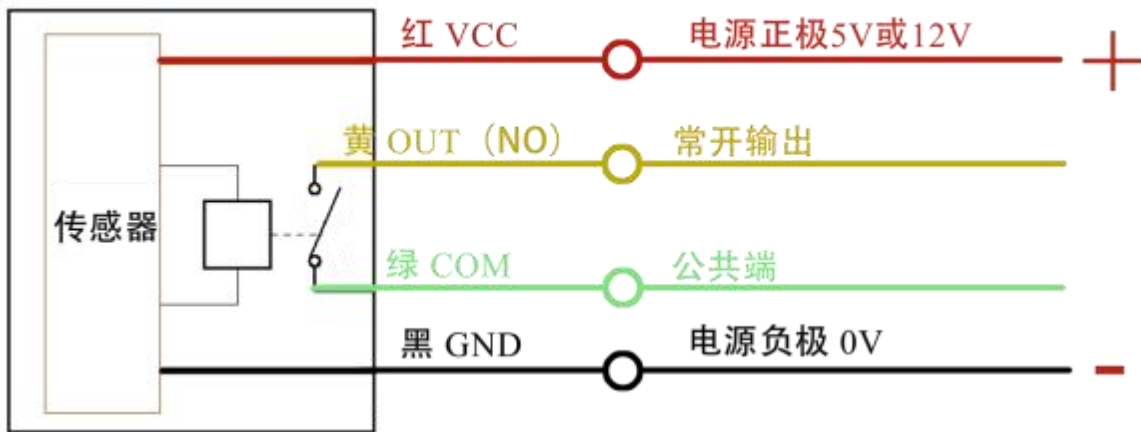

深圳市星科创科技有限公司

Shenzhen XingKeChuang Technology Co., Ltd.

2.

3.

()

()

()

()

(

),

()

(

/ : ,

12

DOA

7

(

() • D

Ö

VEDE. D

D

E

je

ç

